

## SPIR-F SPECIAL 0–2 HOURS PRESENCE DETECTOR

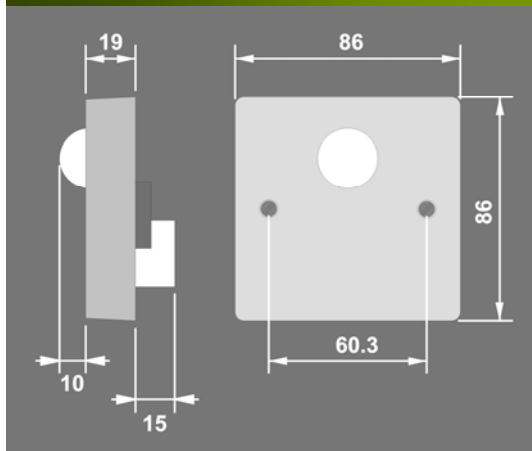

## DESCRIPTION AND OPERATION

The SPIR-F series of presence detector switches are designed to provide automatic control of lighting, heating or ventilation loads. They detect movement using a PIR sensor and turn the load on. When an area is no longer occupied the load will switch off after an adjustable time out period.

An optional internal light sensor provides additional energy saving in lighting applications (SPIR-LSF). When an area is occupied lighting is only switched on when the level of natural light is below a preset level.

When the unit is first powered up the PIR sensor will always detect immediately regardless of whether the room is occupied. A selectable power up delay allows the installer to choose whether the load comes on immediately when the unit is powered up or is kept off for a small time (about 40 seconds) to allow the sensor to settle.

## WIRING

Wire the SPIR-F products as in the diagram.

To switch from more than one position simply wire two or more units in parallel to achieve two way and intermediate switching.

The detector should be sited so that the occupants of the room fall inside the detection pattern shown overleaf, at a recommended height of 1.2m to 1.5m for wall sensors. Note that the higher the sensor is installed the shorter the detection range will be.

- Avoid direct sunlight entering the sensor.
- Do not site within 1m of forced air heating or ventilation.
- Do not site within 1m of any lighting.
- Do not fix to a vibrating surface.

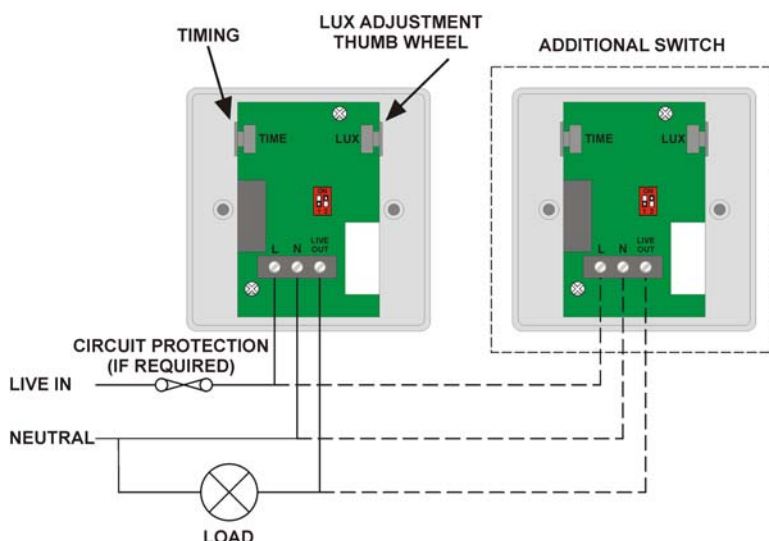

## INSTALLATION

**Warning.** This device works at mains potential. Be sure to take care when working with electricity.

1. Make sure the load is connected and in working order.
2. Isolate the mains supply to the circuit at the main consumer unit.
3. Connect the controller via the terminal block. Live supply to the L terminal, Neutral to the N terminal and the load to the LIVE OUT terminal.
4. If fitted set the LUX level thumbwheel fully clockwise.
5. Set the time to minimum (fully anticlockwise) and set both switches to ON (0-2 hour range, no power up delay) according to the chart below.



6. Screw the unit to the wall and switch the mains supply back on at the distribution board.
7. The load should come on immediately.
8. Vacate the room or remain very still and wait for the load to switch off (should take no more than 2 minutes).
9. Check that the load switches on when movement is detected.
10. Now set the final LUX level and timing by isolating mains supply to the circuit at the main consumer unit.
11. To set the LUX level wait until the level of natural daylight is just enough that lighting is required. Starting with the LUX thumbwheel fully anticlockwise. Very slowly turn the thumbwheel clockwise until the lights come on. Note that when the LUX thumbwheel is fully clockwise then the lights will **always** come on with occupancy.
12. Select the time out range using the switch 1 according to the chart below. Set the time out period using the thumbwheel, fully clockwise is the maximum (either 2 hours or 4 hours depending on the range).
13. If required, select the power up delay (to prevent the load coming on immediately on power up).
14. Screw the unit to the wall and switch the mains supply back on at the distribution board.

## DETECTION PATTERN

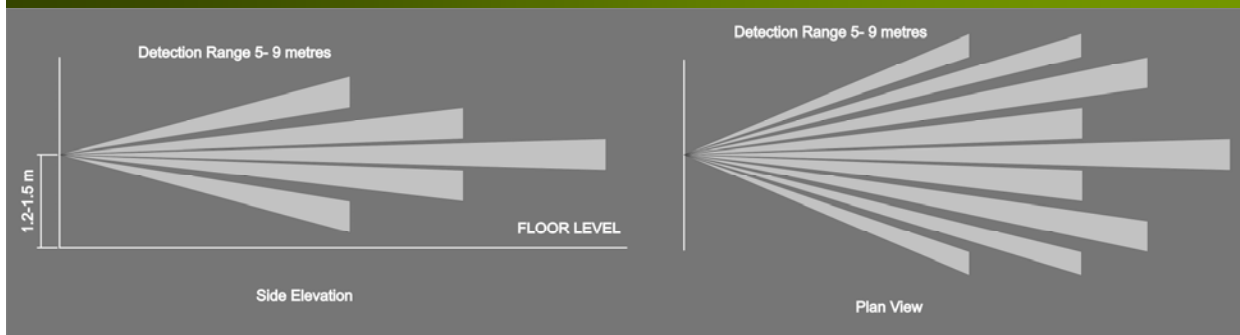

## FAULT FINDING

### LOAD DOES NOT COME ON

Check to see if the live supply to the circuit is good. Strap across the *L* and *LIVE OUT* terminal to turn the load on.

For LUX versions only, if the supply and wiring are good, check the LUX level setting. Increase the LUX level setting to allow the controller to turn on at higher ambient natural light level.

### LIGHTS DO NOT GO OFF

Ensure that the area is left unoccupied for a greater time period than the time out period set using the switch.

Make sure that the sensor is not adjacent to circulating air, heaters or lamps.

## SPECIFICATION

### LOAD

16 Amp resistive load  
 10 Amp incandescent lighting  
 6 Amp fluorescent lighting  
 3 Amp compact fluorescent lighting  
 3 Amp low energy lighting  
 3 Amp low voltage lighting (switch primary of transformer)  
 Fluorescent lighting (max 6 fittings recommended)  
 For fluorescent lighting total power factor correction capacitance must not exceed 40µF.  
 3 Amp fans and ventilation equipment  
 Switch SON lighting loads via a contactor

**SUPPLY VOLTAGE** 220-240 Volts AC 50 Hz  
**TIME OUT PERIOD** Adjustable 10 seconds to 4 hours in two ranges  
**LIGHT LEVEL** Optional adjustment by thumbwheel light to dark.  
**FIXING METHOD** Surface fixing 25mm deep plastic surface mount moulded box.  
 Flush fixing 25mm steel wall box or 32mm deep cavity wall box.

**TERMINAL CAPACITY** 4.0mm<sup>2</sup>  
**MATERIAL** Flame retardant ABS  
**TYPE** Class 2  
**TEMPERATURE** -10°C to 35°C  
**CONFORMITY** EMC-89/336/EEC  
 LVD-73/23/EEC



## PART NUMBERS

SPIR-F ST 0-2 HOURS Wall mounted presence detector  
 SPIR-LSF ST 0-2 HOURS Wall mounted presence detector with integral light sensor

### IMPORTANT NOTICE!

This device should be installed by a qualified electrician in accordance with the latest edition of the IEE wiring regulations.

Due to our policy of continual product improvement CP Electronics reserves the right to alter the specification of this product without prior notice.

**C.P. Electronics Ltd**  
 Unit 2 Abbey Manufacturing Estate  
 Mount Pleasant, Wembley  
 Middlesex. HA0 1RR

Tel: + 44 (0) 20 8900 0671  
 Fax: + 44 (0) 20 8900 0674  
[www.cpelectronics.co.uk](http://www.cpelectronics.co.uk)  
[enquiry@cpelectronics.co.uk](mailto:enquiry@cpelectronics.co.uk)



FMA5709

