

MRT16-WP WEATHERPROOF MULTI-RANGE TIME DELAY SWITCH (SPECIAL TIMING VERSION 4 HOURS)

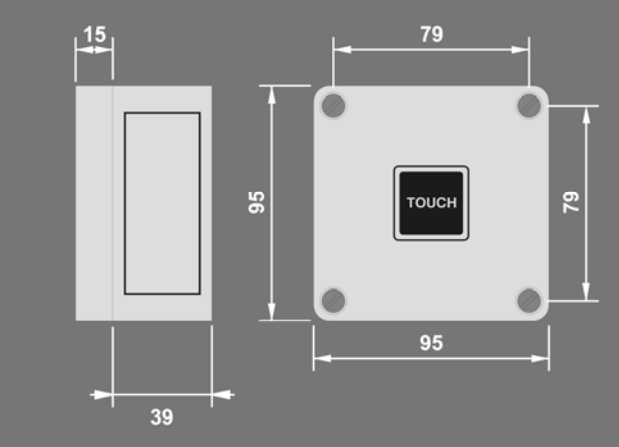

DESCRIPTION AND OPERATION

The MRT16 series of time delay switches are designed to provide timed control of lighting, heating or ventilation loads. Using touch (light press required) activation the user can switch on a load for a preset time period and have the load turn off automatically after the time period has elapsed.

Multiple timing ranges come as standard to allow the time out period to be set accurately. Time setting is achieved using switches and a thumb-wheel at the rear of the unit.

Several modes of operation are selectable using switches:

- On/off: triggering the timer will turn on the load and start the timing. Triggering the timer again during timing will immediately turn off the load and stop the timing.
- Resetting: triggering the timer will turn on the load and start the timing. Triggering the timer again during timing will re-start the timing period from scratch. When using an external trigger In this mode, the timer will not start until the trigger is removed making it ideal for pump or fan overrun applications.
- Non-resetting: triggering the timer will turn on the load and start the timing. Triggering the timer again during timing will have no affect.

Optional neon indicators provide permanent illumination or illumination during the timing period.

WIRING

Wire the MRT16 timers as in diagram 1. Connection to the TRIG terminal is optional.

Applying a live to the trigger terminal will start the timer running. A momentary switch can be used, for example, in corridor lighting applications. A permanent input can be used, for example, in pump overrun applications.

To switch from more than one position simply wire two or more units in parallel to achieve two way and intermediate switching.

For lighting applications that call for the replacement of a three wire switching system follow diagram 2.

When installing touch switches do not fix to a vibrating or uneven surface.

Ensure that all cable entry to the enclosure is via suitable cable glands and seal with silicone sealant where appropriate.

If it is necessary to screw through the rear of the enclosure, ensure that any holes are covered with the caps provided and sealed with silicone sealant where appropriate.

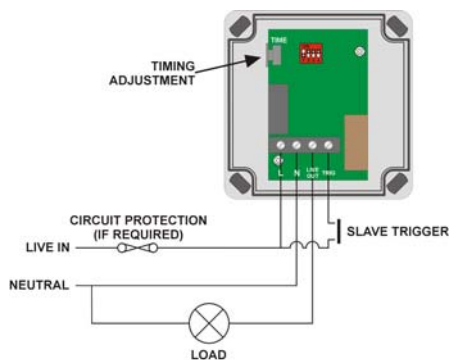

Diagram 1 Standard Wiring

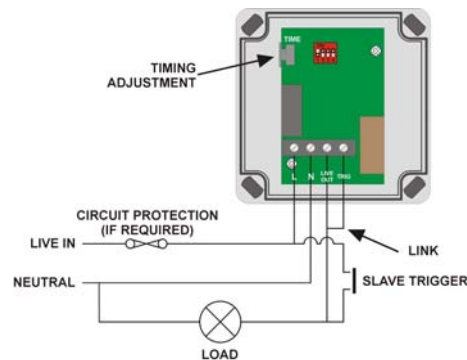
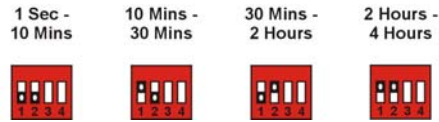

Diagram 2 Wiring for three wire switching circuits

INSTALLATION

Warning. This device works at mains potential. Be sure to take care when working with electricity.

1. Make sure the load is connected and in working order.
2. Isolate the mains supply to the circuit at the main consumer unit.
3. Connect the controller via the terminal block. Live supply to the *L* terminal, Neutral to the *N* terminal and the load to the *LIVE OUT* terminal. Where required connect the external trigger to the *TRIG* terminal.
4. Set the timing range according to the diagram below. Set the thumbwheel to the time setting (anticlockwise is minimum, clockwise is maximum).



5. Set the function according to the diagram below (see above for description).

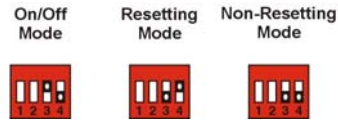

6. Screw the unit to the wall and switch the mains supply back on at the distribution board.

FAULT FINDING

LOAD DOES NOT COME ON

Check to see if the live supply to the circuit is good. Strap across the *L* and *LIVE OUT* terminal to check.

LOAD DOES NOT GO OFF

Check that the time setting is correct.

When using external triggers, ensure that live is removed from the trigger terminal to enable the timer to start (for resetting mode only).

SPECIFICATION

LOAD

16 Amp resistive load
10 Amp incandescent lighting
6 Amp fluorescent lighting
3 Amp compact fluorescent lighting
3 Amp low energy lighting
3 Amp low voltage lighting (switch primary of transformer)
Fluorescent lighting (max 6 fittings recommended)
For fluorescent lighting total power factor correction capacitance must not exceed 40µF
3 Amp fans and ventilation equipment
Switch SON lighting loads via a contactor

SUPPLY VOLTAGE 220-240 Volts AC 50 Hz
TIMING PERIOD Adjustable 1 second to 4 hours in ranges
TERMINAL CAPACITY 4.0mm²
IP RATING IP 66
MATERIAL Polystyrene
TYPE Class 2
TEMPERATURE -10°C to 35°C
CONFORMITY EMC-89/336/EEC LVD-73/23/EEC 

PART NUMBERS

MRT16-WP ST 4HRS	Weatherproof multi-range timer 4 hour timing
/PN	Permanently illuminated neon
/TN	Temporarily illuminated neon (only illuminates during timing)

IMPORTANT NOTICE!

This device should be installed by a qualified electrician in accordance with the latest edition of the IEE wiring regulations.

Due to our policy of continual product improvement CP Electronics reserves the right to alter the specification of this product without prior notice.

C.P. Electronics Ltd
Unit 2 Abbey Manufacturing Estate
Mount Pleasant, Wembley
Middlesex. HA0 1RR

Tel: + 44 (0) 20 8900 0671
Fax: + 44 (0) 20 8900 0674
www.cpelectronics.co.uk
enquiry@cpelectronics.co.uk



FMA5709

