

ENERSTAT-PIR ELECTRONIC THERMOSTAT

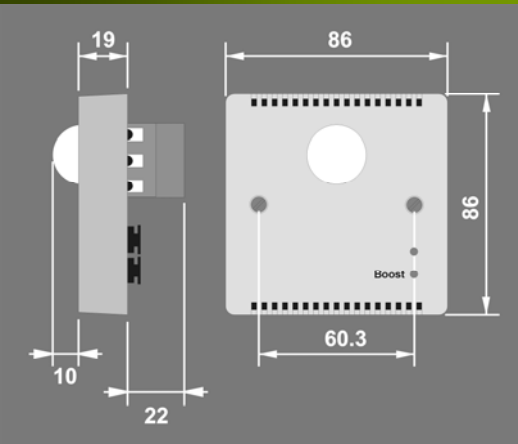

DESCRIPTION AND OPERATION

The ENERSTAT-PIR electronic thermostat will accurately maintain the temperature of a room at two levels (or setpoints): the setback temperature and the boost temperature. The boost temperature is automatically selected using a PIR (passive infrared) occupancy detector which detects moving body heat.

Normally the lower setback temperature level is maintained. When occupancy is detected by the PIR sensor the higher boost level is selected; when occupancy is no longer detected and after an adjustable time period the unit reverts to using the setback temperature.

Typically the setback level would be used to maintain background heat in a room. When the room is occupied, the boost level provides a comfortable heat, but only while the room remains occupied.

The ENERSTAT-PIR can directly switch a heating load making it ideal for the control of panel heaters.

WIRING

Wire the ENERSTAT-PIR as in the diagram.

To get accurate temperature measurements, siting the unit in the correct location is important:

- Always mount onto a wall not a ceiling
- Do not install above a heater
- Allow a clearance of 500mm from the heater being controlled and 1m from forced air heating or ventilation
- Avoid installing near drafts of airflow
- Ideally install at a height of 1.2m to 1.5m
- Do not cover the slots at the top and bottom
- Mounting on an internal wall or partition gives the best measurement accuracy
- Avoid direct sunlight entering the PIR sensor
- Do not fix to a vibrating surface

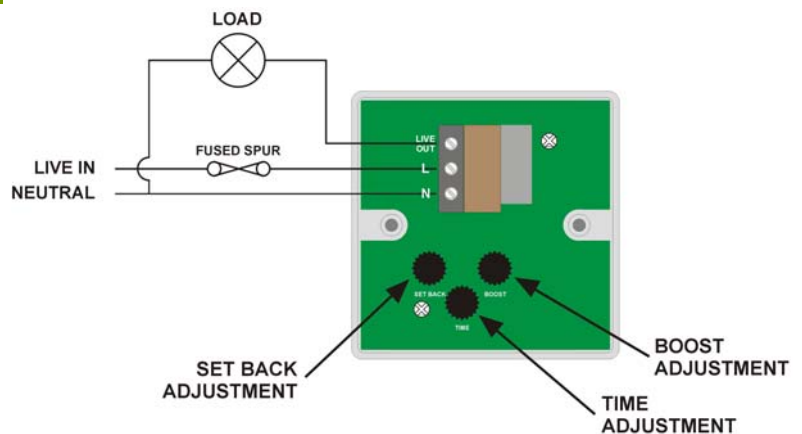

INSTALLATION

Warning. This device works at mains potential. Be sure to take care when working with electricity.

1. Make sure the load is connected and in working order.
2. Isolate the mains supply to the circuit at the main distribution board.
3. Adjust the setback, boost and time settings according to the diagram.



4. Connect the controller via the terminal block. Live supply to the *L* terminal, Neutral supply to the *N* terminal and the load to the *LIVE OUT* terminal.
5. Screw unit to the wall and switch the mains supply on.
6. If the heater has its own internal thermostat, turn this to maximum.
7. When the RED LED is lit, this indicates that the unit is supplying power to the heater.
8. When the GREEN LED is lit, the unit is using the BOOST temperature.
9. Wait approximately 1 minute for the thermostat to operate.
10. The heater will now come on only if the temperature in the room is less than the thermostat setpoint.
11. Due to variations in room size, heater efficiency, airflow, mounting position, drafts etc. the temperature settings on the dial s should be used as guidance only. It may be necessary to adjust the unit to different settings in order to achieve the required temperatures.
12. To test that the unit is functioning correctly, repeat from step 2 and select maximum boost temperature and minimum timing.
13. To test the PIR detector set to minimum timing. Stay extremely still for approximately 40 seconds and wait for the green light to go out. Subsequent movement should bring the green light on again.

DETECTION PATTERN

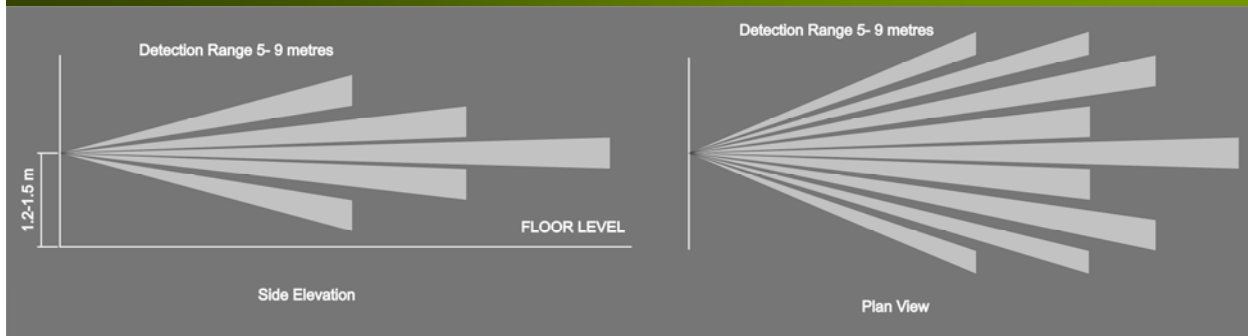

FAULT FINDING

HEATER DOES NOT COME ON

Note that there is a delay of approximately 1 minute from power being applied before anything happens.

Check that the temperature in the room is below the setpoint. If not, then the heater will not come on. Adjust the temperature settings accordingly.

Check that the boost has been selected—the green light should be on. If this has not been selected then the lower setback temperature setting will be used.

Check the circuit by strapping across L and LIVE OUT terminals.

BOOST LIGHT DOES NOT COME ON

Note that there is a delay of approximately 1 minute from power being applied before anything happens.

Check that the unit is powered up by measuring the supply voltage across L and N

BOOST LIGHT STAYS ON

The boost light will stay on when occupancy is detected.

ROOM TOO COLD

Check that the heater is working and the thermostat on the heater is turned to maximum.

Check the temperature settings and increase if necessary.

Make sure that the thermostat is not installed above or near to the heater.

SPECIFICATION

LOAD

16 Amp resistive heating
Not suitable for controlling quartz heaters

SUPPLY VOLTAGE

220-240 Volts AC 50 Hz

TIME OUT PERIOD

Adjustable 30 seconds to 4 hours

SETBACK TEMPERATURE

Adjustable 5°C to 20°C

BOOST TEMPERATURE

Adjustable 10°C to 30°C

FIXING METHOD

Surface fixing 25mm deep plastic surface mount moulded box.
Flush fixing 35mm steel wall box (ensure top and bottom lugs are removed) or 35mm deep cavity wall box.

TERMINAL CAPACITY

4.0mm²

MATERIAL

Flame retardant ABS

TYPE

Class 2

TEMPERATURE

-10°C to 40°C

CONFORMITY

EMC-89/336/EEC

LVD-73/23/EEC



IMPORTANT NOTICE!

This device should be installed by a qualified electrician in accordance with the latest edition of the IEE wiring regulations.

Due to our policy of continual product improvement CP Electronics reserves the right to alter the specification of this product without prior notice.

C.P. Electronics Ltd
Unit 2 Abbey Manufacturing Estate
Mount Pleasant, Wembley
Middlesex. HA0 1RR

Tel: + 44 (0) 20 8900 0671
Fax: + 44 (0) 20 8900 0674
www.cpelectronics.co.uk
enquiry@cpelectronics.co.uk



FMA5709

