

SPECIFICATION

SWITCHING LOAD

10A of lighting and or ventilation including incandescent, fluorescent, compact fluorescent, low voltage (switch primary of transformer).

Dimming units:

For DSI or broadcast DALI 20 ballasts, maximum dimming pair cable length 200m

For DALI read back 1 ballast (+ 1 EMPRO where used), maximum dimming pair cable length 200m

Cable min. 0.75mm²

PERIPHERAL LOAD

The unit can power the following maximum number of peripherals at the stated ambient temperature:

Temperature -10°C to 50°C

EBR-CPIR, LMS-4SC, EBR-BR max 4 units

EBR-MWS3 max 2 units

Temperature 51°C to 80°C

EBR-CPIR, EBR-4SC, EBR-BR max 2 units

EBR-MWS3 max 1 unit

SUPPLY VOLTAGE 220-240 Volts AC 50 Hz

TERMINAL CAPACITY 2.5mm²

MATERIAL Flame retardant ABS

TYPE Class 2

TEMPERATURE -10°C to 80°C

CONFORMITY EMC-89/336/EEC 

LVD-73/23/EEC

PART NUMBERS

LMS-MIN-LCM	Rapid single channel LCM
LMS-MIN-LCM-DIM	Rapid single channel LCM DALI/DSI/EMPRO
LMS-MIN-LCM-EM	Rapid single channel LCM EM version
EBS-LCDHS	Programming handset
EBR-CPIR	PIR presence detector
EBR-MWS3	Microwave presence detector
EBR-BR	Bus repeater
EBR-4SC	Scene panel
RJ45-SPLIT	Network 3-way splitter
RJ45-COUPLE	Network 2-way coupler



IMPORTANT NOTICE!

This device should be installed by a qualified electrician in accordance with the latest edition of the IEE wiring regulations where applicable.

All devices are supplied pre-programmed and identified with a unique reference number. The device must be installed in the position shown on the site installation drawings where the identification number is shown.



C.P. Automated Lighting
A Division of
C.P. Electronics Ltd
Unit 2 Abbey Manufacturing Estate
Mount Pleasant, Wembley
Middlesex. HA0 1RR

Tel: + 44 (0) 20 8900 0671
Fax: + 44 (0) 20 8900 0674
www.cpelectronics.co.uk
enquiry@cpelectronics.co.uk

Due to our policy of continual product improvement CP Electronics reserves the right to alter the specification of this product without prior notice.

Ref: %WD231 Issue 1

PRODUCT DATA AND INSTALLATION SHEET



SINGLE CHANNEL LIGHTING CONTROL MODULE LMS-MIN-LCM, LMS-MIN-LCM-DIM, LMS-MIN-LCM-EM

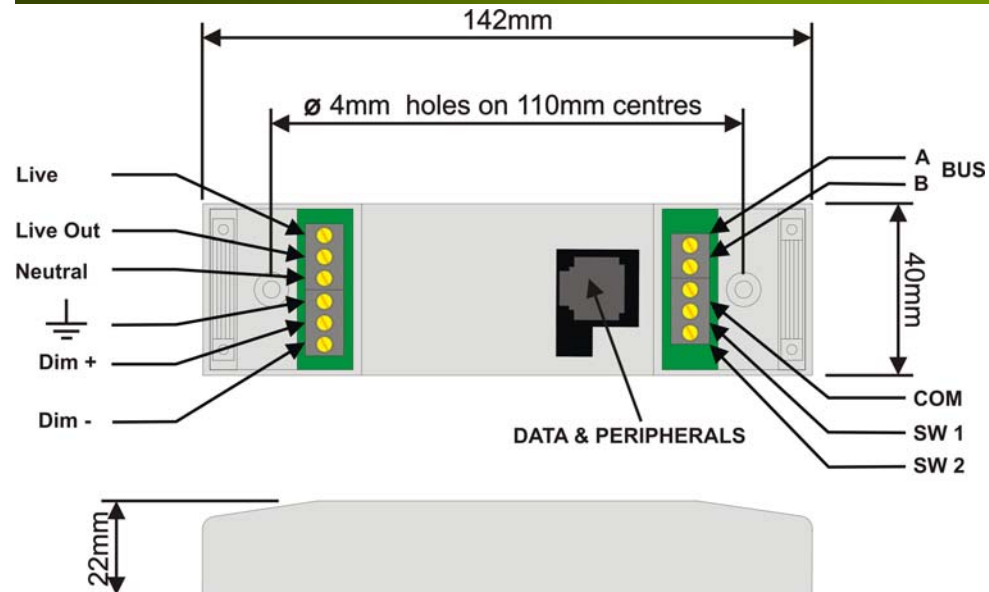

DESCRIPTION AND OPERATION

The LMS-MIN-LCM series of lighting control modules (LCMs) are used as part of the LMS Lighting Management System to switch lighting. They have a single addressable output port for switching, whilst the DIM model provides DSI and DALI dimming signals for dimmable luminaires. For emergency test applications which require centralised testing or ELV switch connections, the LMS-MIN-LCM-EM provides a switched permanent live output. Incorporated on the unit is a two channel interface for connection to external devices such as light switches, emergency test switches and time clocks. A port on the front enables the LCM to be connected to peripherals such as presence detectors and bus repeaters, and two terminals allow connection to the LMS bus.

The dimming version LMS-MIN-LCM-DIM provides support for DALI EMPRO emergency test and monitoring. When this method is being used for emergency testing, do not use the LMS-MIN-LCM-EM product—this is only for switched emergency test.

The LCM offers many features including:

- Power for up to 4 peripherals
- Adjustable off delays and group delays
- Adjustable start up lighting levels
- Scene control
- Bus and activity LEDs

INSTALLATION AND WIRING

Warning. This device works at mains potential. Be sure to take care when working with electricity.

- Install the LCM in the position indicated on the installation drawings.
- Where the unit is installed in a luminaire, take into account the temperature parameters in the specification section.
- Screw fixings can be found inside the wiring compartment.
- **Ensure that the programming window is accessible and visible.**
- Connect a permanent supply to the Live, Neutral and Earth terminals.
- Connect luminaires to the output of the LMS-MIN-LCM and LMS-MIN-LCM-DIM units using diagram 1.
- Connect emergency fittings to the output of the LMS-MIN-LCM-EM units using diagram 2. Note that the test switch can be wired to any device on the bus, not specifically the EM unit.
- For maintained fittings, two LMS units must be used connecting to the permanent and switched lives.
- Follow the guidelines in the network connections section to wire up the network and peripherals.
- Connect the terminating resistor provided, where shown in the network connections section. Each unit is sent with a terminating resistor. Discard if not required.
- Where specified on the installation drawings, connect switches to the interface connections between the input and common as shown on the diagrams. **Switches must be isolated.**

COMMISSIONING

To bring the lights on prior to commissioning, do one of the following:

- From the LCM user menu of the programming handset, select *override on Y*, send this to each individual box. Note that if the power is reset, this action will need to be performed again.
- Alternatively from the LCM programming menu select *power up on Y*, send this to each individual unit and reset the power. This option may need to be cancelled when the unit is properly commissioned.

Commissioning will normally be performed by our trained commissioning engineers. Please note that prior to commissioning, it is the responsibility of the installing contractor to ensure the following:

- The units must be connected and installed as described in these instructions
- Mains power must be available
- Luminaires must be connected and in working order
- Bus connection must be established and checked

The LCM can be set up using our infrared programming handset or computer front end. For programming details see the separate programming document.

Network Connections—repeater

Where the limit for the number of devices has been exceeded, a bus repeater (EBR-BR) can be used to extend the network; see diagram 6 for connection details. Note that the repeater contains terminating resistors, so there is no need to fit extras.

Alternatively the bus rate can be lowered during the commissioning process.

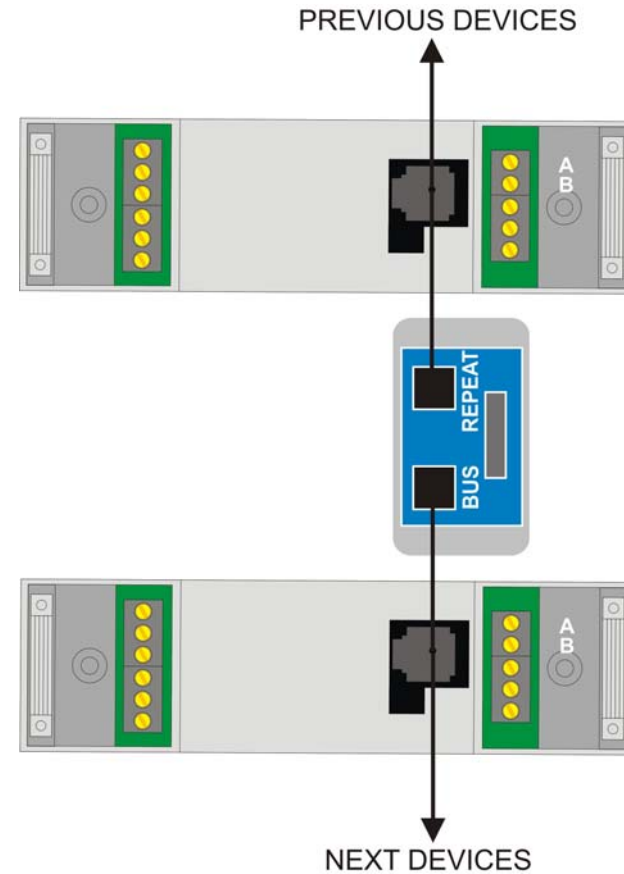

Diagram 6

Network Connections—pluggable

As an alternative to a hardwired network, the network can be constructed using pluggable RJ45 patch cords. The advantage of this method is that the bus wiring can be prepared off-site. Note that a number of 3 way splitters (RJ45-SPLIT) will be required as shown in diagram 5. Using this cable a network length up to 500m can be achieved using the highest bus rate setting with 40 devices attached.

Where the limit for the number of devices has been exceeded, a bus repeater (EBR-BR) can be used to extend the network; See diagram 6 for connection details. Alternatively the bus rate can be lowered during the commissioning process.

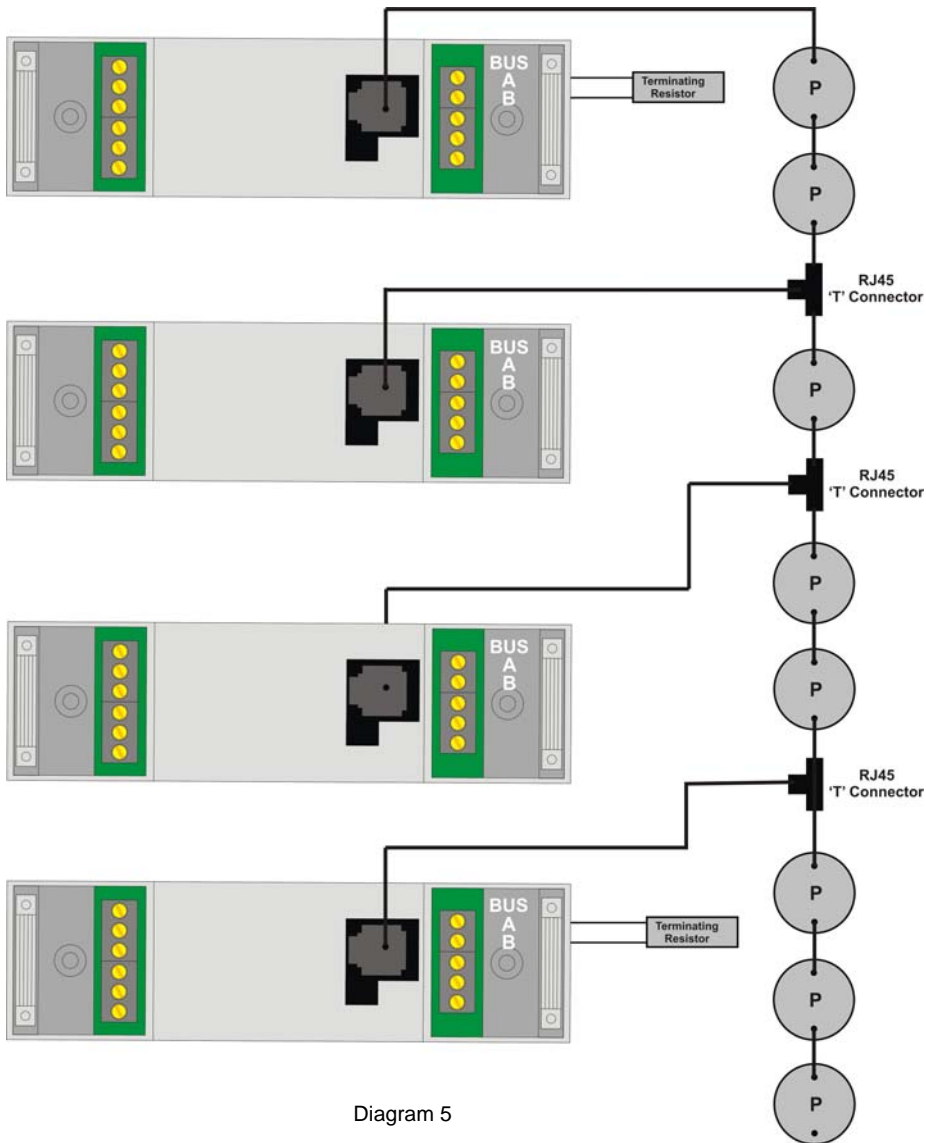

Diagram 5

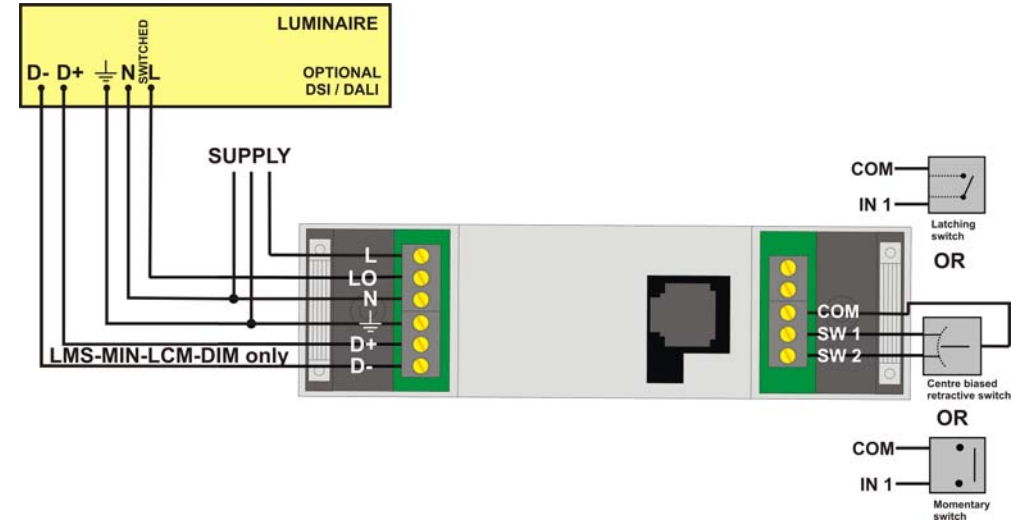

Diagram 1 LMS-MIN-LCM(-DIM) wiring

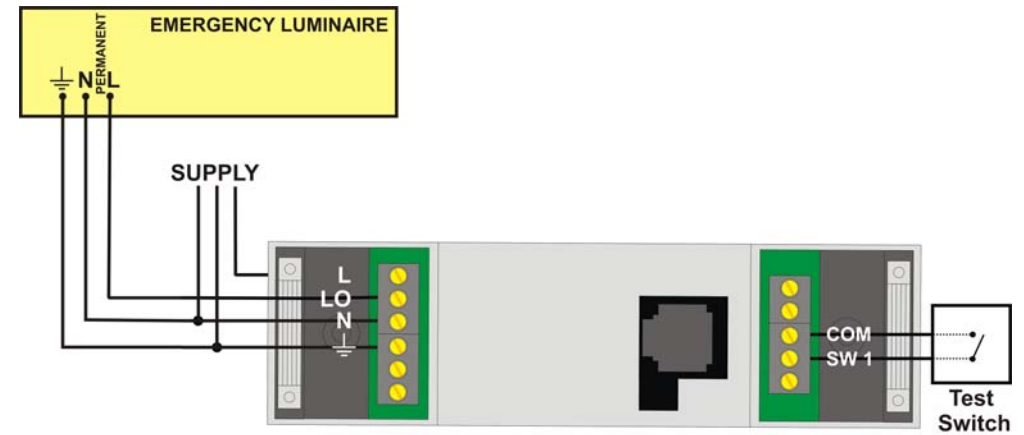

Diagram 2 LMS-MIN-LCM-EM wiring

NETWORK CONNECTIONS

Network Connections—2 devices only

For simple systems where only two switching devices are required, connect as shown in diagram 3. Ensure that terminating resistors are connected to each device (supplied). The EBR-CPIR and EBR-MWS3 devices have 2 ports and can be connected in this way; for other peripheral devices hardwiring to an RJ45 plug may be necessary, with the network wired using the bus terminals.

Peripherals can be daisy-chained from the port as shown, subject to the maximum rating per unit.

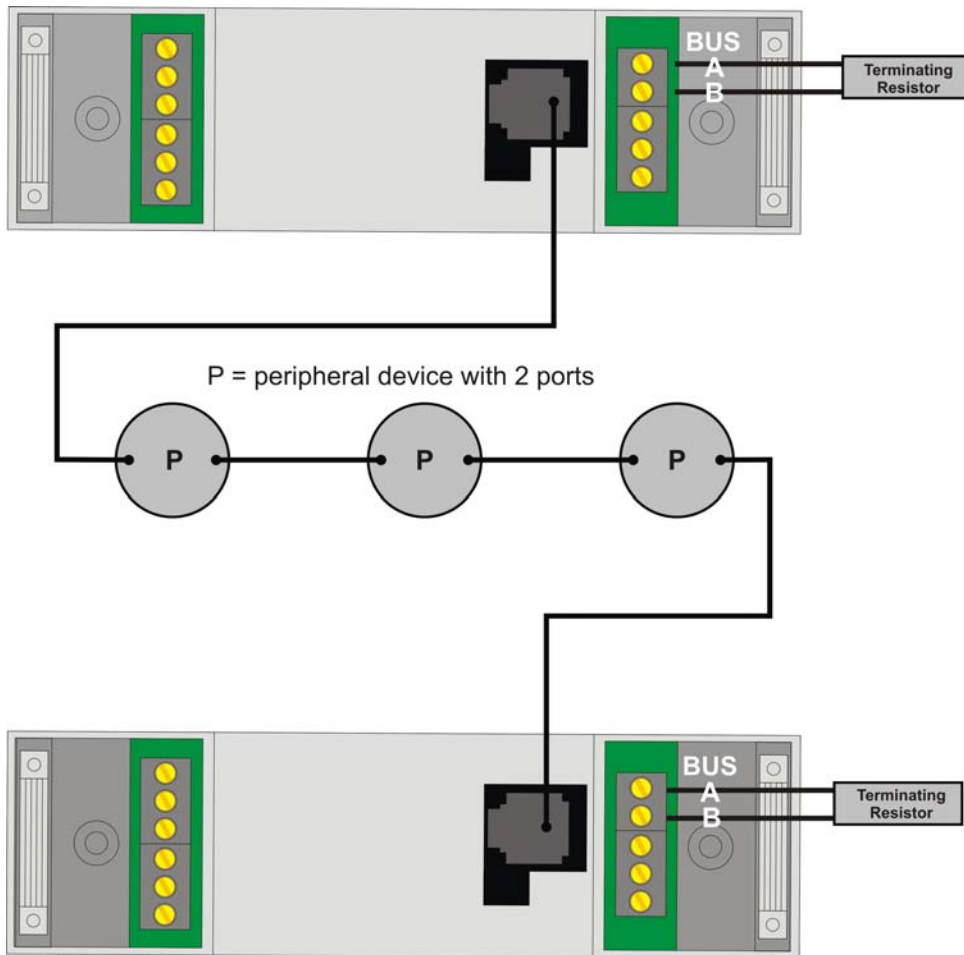

Diagram 3

Network Connections—hard-wired

For the majority of applications a hardwired network is most suitable, as shown in diagram 4. It allows any number of devices to be connected and wired using two core cable. An unshielded twisted pair (UTP) cable such as Belden 8471, 9740 is recommended. Using this cable a network length up to 400m can be achieved using the highest bus rate setting with 40 devices attached.

Where the limit for the number of devices has been exceeded, a bus repeater (EBR-BR) can be used to extend the network; see diagram 6 for connection details. Alternatively the bus rate can be lowered during the commissioning process.

Peripherals can be daisy-chained from the port as shown, subject to the maximum rating per unit.

Note: the bus connections are polarity sensitive.

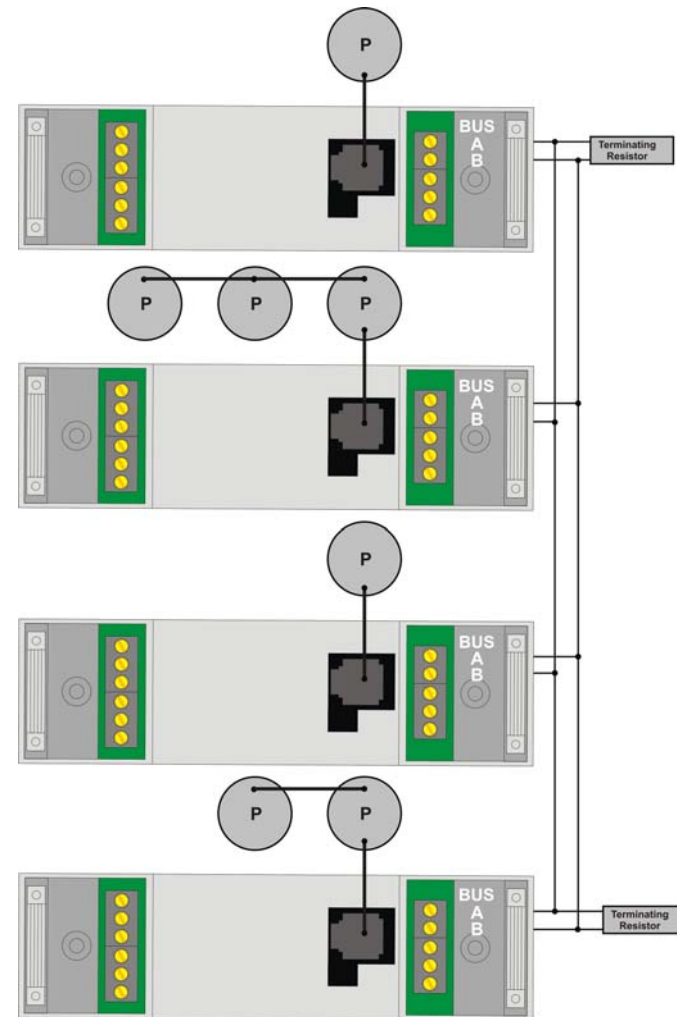

Diagram 4